

Smart Modular Solution



Product Overview

Smart Modular gas meter is a new product based on IoT technology and market application requirements. This product adopts independent plugged modular structure design. The smart modular can be installed on the reserved external interface of steel casing/aluminum casing diaphragm gas meter. According to customer requirements and local network coverage, NB-IoT, GPRS, LoRa/LoRaWan communication modules are available.

Features

- Independent Design:
The smart modular is completely independent design and can be freely plugged with mechanical meter;
- Easy installation: It can be used as an ordinary mechanical meter in the early stage and can be upgraded to an IoT gas meter without complex operations in the later stage;
- Various IoT modules available
- Functions of 3D anti-tamper, meter alarm linkage, alarm of micro-flow and overload flow are optional;

Specifications

Model	DCM
Working temperature(°C)	-25~+55
Protection level	IP65
Data acquisition	Double pulse (0.01m ³)
Communication mode	NB-IoT/GPRS/LoRa/LoRaWan/ GPRS+IR(Type B&C module)
Power supply	3.6V Lithium battery(replaceable), 8 to 10 years(report one time daily)
Data storage	10 Years

Dimension

Structure A (Galvanized steel)

Model	A(mm)	B(mm)	C(mm)
G1.6S-GI	90 ± 0.50 110 ± 0.50 130 ± 0.50	M26 x 1.5 - 6 g	228
G2.5S-GI		M30 x 2 - 6 g	
G4S-GI		G¾B	
WG2.5S-GI		G1B	
		G1¼B	226

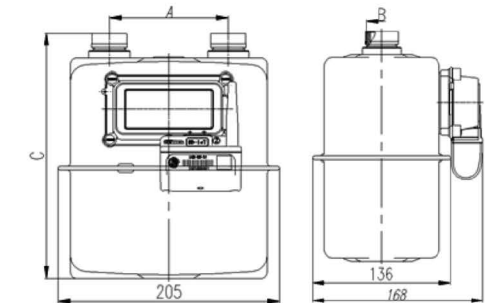

G1.6S-GI / G2.5S-GI / G4S-GI / WG2.5S-GI

Structure B

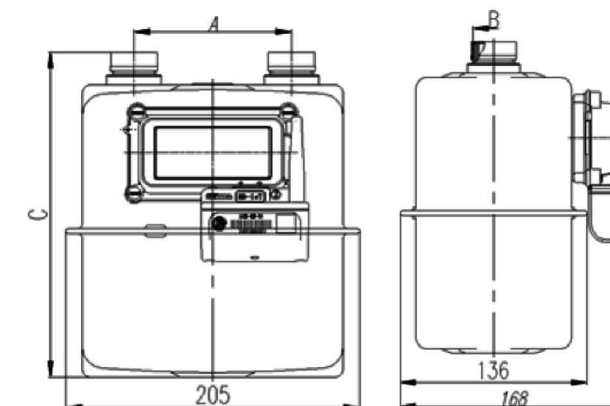

Structure C

